

FUNCTIONAL DEVICES INC.

POWER-LINE CARRIER

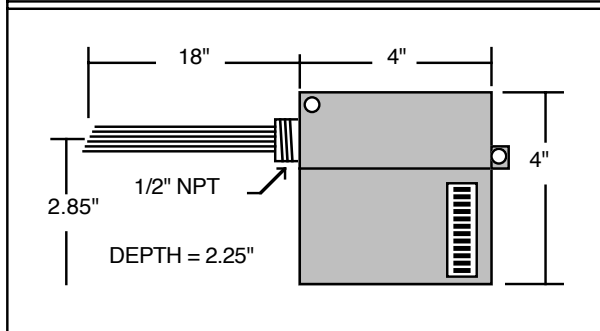

MODEL RL
LATCHING DIGITAL-IN RESPONDER (2-WAY)

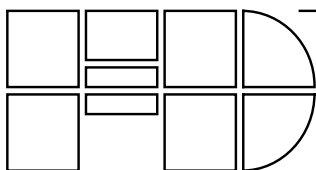

DESCRIPTION & OPERATION

RLs detect momentary contact closures, which might be missed by other two-way Responders due to the fact that other Responders only report the status of the input contact at the instant they are polled. RLs have no output relays but they have two latching inputs, each one of which can be DIP switch selected to be latch on OPEN or latch on CLOSE (normal is CLOSED or normal is OPEN, respectively). If either input circuit is momentarily non-normal, it will latch and the next time the Responder is polled it will report a closed digital in (DI) to the Command Synthesizer which will report a closed DI to the controller. The latching input circuits within RL can only be returned to normal by an analog query command from the Command Synthesizer and then only when the input to the circuit has returned to its normal state. The Command Synthesizer will only attempt this reset after it has reported the existence of the non-normal condition to the controller.

RL latching Responders are not presently applicable to PLC systems using CD Command Synthesizers since the CD does not have a way of identifying that the Responder is of the RL type and cannot discretely execute the return-to-normal analog query command. RLs can only be applied to two-way customized PLC energy management systems in which the Command Synthesizer knows which IDs have been assigned to an RL Responder and in the event of a non-normal event, can decide whether or not to send the analog query command.

RLs can be programmed by setting the positions of switches to assume a unique digital code or identity (ID). The last letter in the model number indicates the channel (carrier frequency) the Responder receives. In RL01 and RL02 it is normally Channel B for the available 504 IDs. IDs above 504 are forbidden.

An RL Responder may not share the same ID as any other Responder.

FEATURES

- Uses existing ac wires for the communication link
- Two latching input circuits per ID, each of which is programmable to be latch on make or latch on break
- Field-programmable DIP switch
 504 IDs
 Input 1 latch on MAKE / BREAK
 Input 2 latch on MAKE / BREAK
- Easy to install
- Excellent diagnostics
- Built-in microprocessor with fail-safe circuit
- 120 or 277 Vac power input

OPTIONS

RL01/B is for use with 120 Vac in cases F, G & H of Drawing 2 in Technical Reference Manual A234
 RL02/B is for use with 277 Vac in case A of Drawing 2 in Technical Reference Manual A234

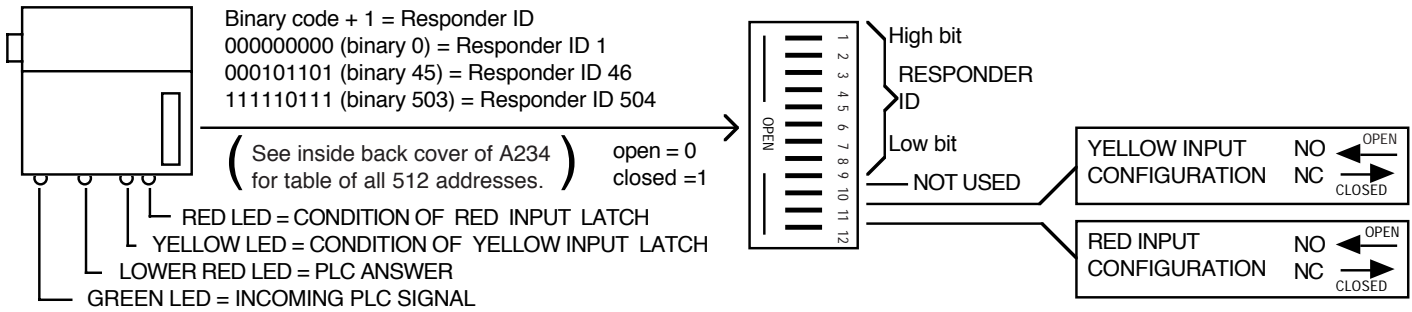

SPECIFICATIONS

RESPONDERS	POWER		
RL01/B	120 Vac	60 Hz	1.2 Watts
RL02/B	277 Vac	60 Hz	1.2 Watts

- Input circuit maximum voltage = +29V dc on common BLUE wire. YELLOW wire to BLUE wire = YELLOW digital in. RED wire to BLUE wire = RED digital in. A CLOSE input requires 0.1 mA.
- Maximum wire run from Responder to dry-contact input switch with 20-gauge wire (shielded) = 100 feet.
- Non-normal condition of YELLOW digital-in is indicated by the lighting of a yellow LED on Responder.
- Non-normal condition of RED digital-in is indicated by the lighting of a red LED on Responder.
- DIP switch 11 OPEN makes YELLOW digital-in be normally open (latch on MAKE). DIP switch 11 CLOSED makes YELLOW digital-in be normally closed (latch on BREAK).
- DIP switch 12 OPEN makes RED digital-in be normally open (latch on MAKE). DIP switch 12 CLOSED makes RED digital-in be normally closed (latch on BREAK).
- Minimum sensitivity of 10 mV peak-to-peak PLC.
- Absolute rejection of all signals outside of + / - 0.8% of channel center
- PLC communication is two-way and has confirmation means, redundancy and continuous refresh.
- Operating temperature range -30° to 150° F, storage temperature range -40° to 185° F.
- Humidity range = 5 to 95% (noncondensing).
- Contains externally visible LEDs, which show the presence of incoming PLC signal, the status of the two digital-in circuits and the occurrence of PLC answers.
- Three-piece housing 4" X 4" X 2.25" of 94-5V flame retardant grey plastic, mountable via attached 1/2" NPT nipple or via screw mounts. Electronics portion is separable from mounting/wiring portion.
- UL listed under standard 916 Energy Management Equipment. RL01C/A is CSA Certified.