

# FUNCTIONAL DEVICES, INC.

## POWER-LINE CARRIER

### Intelligent Responders

- UC202 + TDC2 - IntelliStat Unit Controller
- UC301 + M24PPY or BD55 - Condominium Controller
- UC311 - Multiple Switch Reader

We have assigned the term **Responder** to Power-Line Carrier (PLC) devices that are limited to performing digital-out (DO), digital-in (DI), analog-in (AI), analog-out (AO) and pulse count in/out functions. In addition to these requirements for Responders there are requirements at the location of the Responder for remote intelligence, such as closed-loop control, local decision making or multiple meter reading. We assign the term **Intelligent Responders** to devices that can perform these additional tasks. Their model numbers begin with UC. In all cases the Intelligent Responders can be used in PLC systems along with Responders. Intelligent Responders have — in addition to PLC communication,

DO, DI, AI and AO capability — program storage, electrically erasable data storage and give the installer or user the ability to change some parameters via PLC from the head end and more via a laptop computer or terminal at the location of the Intelligent Responder.

Three of these Intelligent Responders are described in the following pages. These Intelligent Responders were originally designed for specific applications, but in many cases have been altered to meet other customer's requirements. See data sheets A432, D429, D450 and D457 for more information.

### IntelliStat The Intelligent Responder Thermostat System

- UC202 - UNIT CONTROLLER
- TDC2 - TEMPERATURE DISPLAY / CONTROL
- TDC3 - TEMPERATURE SENSOR

#### GENERAL OPERATION

The UC202 (Unit Controller) combined with the TDC2 (Temperature Display/Control) or the TDC3 (Temperature Sensor) form a sub-system in a building-wide setback control system. UC202 is mounted within a heat/cool unit (heat pump or a small packaged heater / air conditioner) where it closed-loop controls the heating and/or cooling. The Unit Controller is hard wired to the wall-mounted TDC2 (or TDC3), which measures room temperature. The TDC2 not only provides user control over the heat/cool unit similar to a conventional wall thermostat, but also provides several important convenience features, including a liquid-crystal display (LCD), which shows room and outdoor temperatures, and heating or cooling status.

From the point of view of the head-end controller this sub-system appears to be a two-way Responder with DO, DI, AI and AO capabilities. Hardware includes a serial link (to a TDC2 or TDC3), a threshold analog-in port (outside compressor coil temperature), and five digital outputs (24 Vac triacs). Two digital inputs allow some increase in deadband during temporary periods of non-occupancy (special order). The UC202 is powered by 24 Vac (supplied by installer and usually present in the heat/cool unit) and has a two-wire connection to an energized ac power line and equipment ground for PLC communication.

When commanded ON via PLC the room temperature is controlled to the set-point temperature. When commanded OFF via PLC the dead band is widened to allow energy savings. The set-point temperature can be changed via PLC. The space temperature and the Unit Controller status can be reported via

PLC to the head-end controller. When used with one-way PLC, head-end control is limited to ON and OFF commands.

The UC202 can be programmed by setting the positions of switches within the UC202 and TDC2 (or TDC3). The UC202 can be programmed to assume a single digital code or identity (ID) or to assume two sequential IDs in order to enable additional PLC communication by means of a second set of DO, DI, AI and AO. The major operating parameters of the Unit Controller, including both operating mode and set-point temperature, can be modified using two-way power-line carrier (PLC). Default values and the operating mode can also be adjusted by a laptop computer or a terminal at the Unit Controller.

The switch selections also allow the UC202 control algorithm and the convenience features of the TDC2 to be controlled and/or limited to conform to what is desired by the installer and the building management. The user can be restricted to limited temperature adjustment. His access to the OVERRIDE ON/OFF mode and the fan AUTO / ON control can also be restricted.

Unit controllers can be intermixed in a PLC system with two-way and one-way Responders to achieve the most cost-effective solution to a given energy management task.

The Unit Controller represents a major step toward distributed intelligence by combining local control of loads with power-line carrier communication. This combination assures continued control of the heat / cool unit even if the head-end control goes down and eliminates the need for running wires.

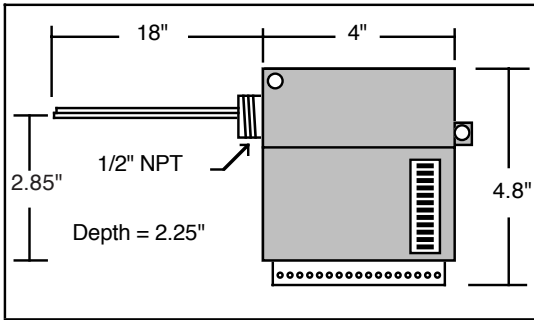

# MODEL UC202 UNIT CONTROLLER



## DESCRIPTION

The UC202 is an Intelligent Responder designed to close-loop control a heat / cool unit (heat pump or small packaged heater / air conditioner). The UC202 is mounted within the heat / cool unit. A power-line carrier (PLC) link with a head-end controller allows operating parameters to be adjusted and output performance to be monitored from the head-end controller. The UC202 requires a TDC2 Temperature Display / Control Unit or a TDC3 Temperature Sensor for operation. See data sheets A432 and D429 for more information.

## FEATURES

- PLC link to head-end eliminates need for hard wiring
- Field-programmable DIP switch for setting PLC addresses and control options
- Built-in microprocessor with fail-safe circuitry
- Easy to install
- Controls either a heat pump or a heater / air conditioner
- Services TDC2 Temperature Display / Control, which allows user control and displays room and outdoor temperatures, ON / OFF and FAN modes. Alternately services TDC3 Temperature Sensor.
- Two digital inputs for use with motion sensor and door switch for minor temperature setback during periods of non-occupancy (optional)
- Excellent diagnostics incorporating 6 LEDs, head-end diagnostics and a liquid-crystal display on the TDC2
- Five triac digital outputs to control contactors or relays for fan(s), compressor(s) and heater(s)

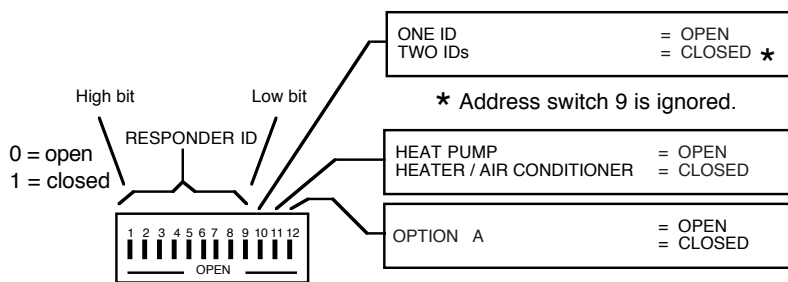

See inside back cover of A234 for complete list of IDs  
 Binary code + 1 = Responder ID  
 00000000 (binary 0) = Responder ID 1  
 000101101 (binary 45) = Responder ID 46  
 111111111 (binary 511) = Responder ID 512

If using a heat pump make Option A open if an energized changeover valve gives heat (closed if it gives cool).  
 If using a heater / AC make Option A open if the fan is controlled by a plenum switch when in heating mode (closed otherwise).

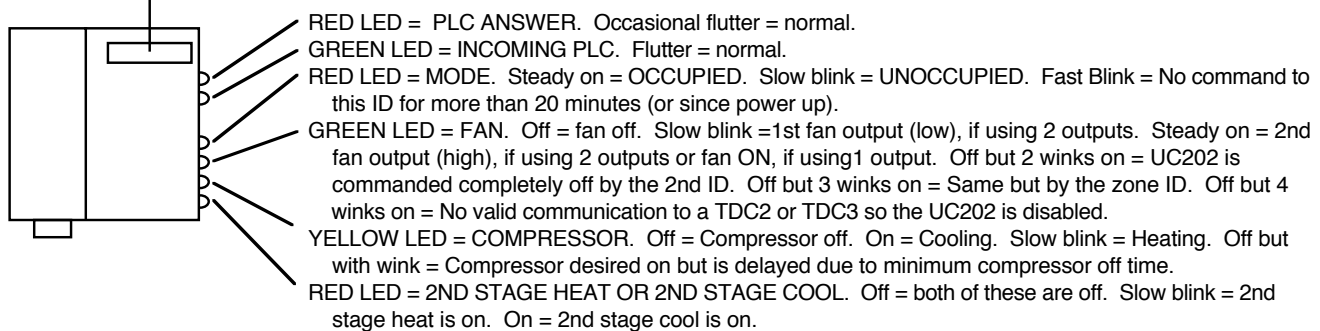

See A475 for information describing power input and signal input.

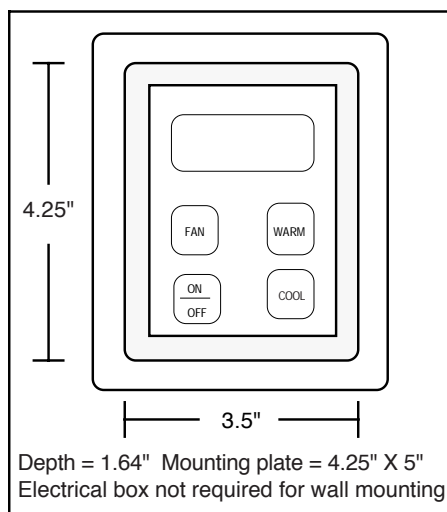

## TDC2 TEMPERATURE DISPLAY/CONTROL

## TDC3 TEMPERATURE SENSOR



### DESCRIPTION

The TDC2 is a Temperature Display / Control Unit for the UC202 Unit Controller. It is mounted on an internal wall and is wired to the UC202. It contains a room-temperature sensor and a liquid-crystal display (LCD) for measuring and displaying the room temperature (temperatures can be displayed in either °C or °F). Outdoor temperature, set-point temperature, the fan's AUTO / ON status and the ON, OFF or OVERRIDE conditions are also displayed on the LCD. Buttons are provided to allow the user to change the room temperature, the FAN condition and the ON / OFF condition. An internal row of switches (DIP switch) allows the installer to select some of the operating parameters of the UC202. The housing has a tamper-resistant feature to prevent the user from changing the performance features.

Model TDC2 is intended for use in hotel / motel, school or commercial buildings. It provides a user-friendly interface for model UC202 and gives the user the ability to adjust his room to a comfortable temperature, which he has every right to expect, but still allows the building management to retain the energy cost savings of off-hour temperature setback. TDC3 provides only the room-temperature sensor. For more information see data sheets A432 and D429.

### FEATURES OF TDC2

- Easy to install
- Contains the room-temperature sensor
- User-friendly
- Contains push buttons for
  - User adjustment of the room temperature
  - User control of the fan condition
  - User control of the on / off condition
- Excellent annunciation includes an LCD display of
  - Room temperature
  - Outdoor temperature
  - Set-point temperature
  - Fan operating condition
  - On / off condition
  - Heating / cooling information
- Contains a 12-position DIP switch for installer to add, delete or modify performance features of the UC202

### DIP SWITCH CONTROL OF PARAMETERS

DS1 = Choice of display in degrees F or C. Open = Fahrenheit. Closed = Centigrade.

DS2 & DS3 limit the user's ability to change the set point. DS2 & 3 open = no change allowed. Only DS2 closed = +/- 3 ° F.

Only DS3 closed = +/- 5 ° F. Both DS2 & DS3 closed = +/- 7 ° F. If displaying in degrees C then 0, 2, 3 or 4° C respectively.

DS4 = Choice of resetting the set point to 72° F or maintaining the previous setpoint after returning to occupied after unoccupied.

DS4 Open = Reset setpoint to 72° when occupied after unoccupied.

DS4 Closed = Retain previous setpoint when occupied after unoccupied.

DS5 = Control over user's ability to implement OVERRIDE OFF. Open = not allowed. Closed = 2 hours override off allowed.

DS6 & DS7 limit the user's ability to implement OVERRIDE ON. DS6 & DS7 open = ability denied. Only DS6 closed = 1/2-hour override on.

Only DS7 closed = 1-hour override on. Both DS6 & DS7 closed = 2-hour override on.

DS8 = Enables use of fan AUTO/ON button (if not enabled then fan remains in AUTO mode). Open = not allowed. Closed = allowed.

DS9 = Choice of 2 stages of cool/fan. Open = 2 cool + 1 fan (or 1 cool + 1 fan). Closed = 1 cool + 2 fan. UC202 can't handle 2 cool + 2 fan.

DS10 = Dead band selection. Open = regular deadband (62 to 86° F). Closed = wide deadband (above 55° F).

DS11 = Hysteresis of heating and cooling (while occupied). Off = Normal (1°F), On = Wide (2°F).

DS12 = Reserved for future use.

## CONDOMINIUM CONTROLLER

In a complex of condominiums, which are occasionally unoccupied for extended periods, considerable energy can be saved by turning down the heat and turning off the water heater when a condominium is known to be unoccupied. Additionally, in applications where electric heat is used and demand charges are applied to the condominium complex by the utility, the heaters of some of the condominiums can be momentarily turned off during occupancy to achieve demand control, thereby reducing the demand charge.

If the temperature has been set back for energy savings or the condominium is simply unoccupied with the heat turned off, provisions should be made to re-enable heat if the temperature gets too low. To accomplish this, the loads can be treated as two load groups: **critical** and **noncritical**. The critical

loads would include sufficient electrical heaters that could be commanded on to insure that freezing does not occur. Noncritical loads would, in general, include the remaining heat and the water heater.

In a condominium that has electric heat, each room typically has its own thermostat, and the electric heat strips are powered by individual circuit breakers. Likewise, if the water heater is electric it will be powered by an individual circuit breaker. Under this circumstance, if Square D "POWERLINK" circuit breakers are installed the Condominium Controller can utilize the circuit breakers to implement time-of-day and demand control. If "POWERLINK" circuit breakers are not installed, relays can be used in series with the existing circuit breakers.

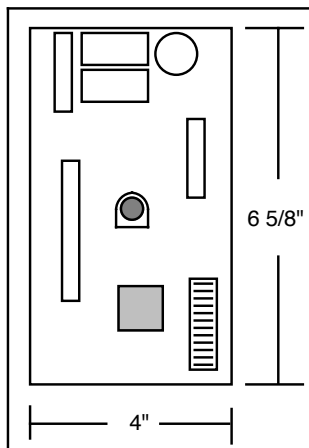

### MODEL UC301 - CONDOMINIUM CONTROLLER

#### GENERAL OPERATION



UL COMPONENT  
RECOGNIZED

The UC301 is an Intelligent Responder designed to handle the energy management task described above where the communication with the head-end controller is via Power-Line Carrier (PLC). In addition to the PLC interface with the ac line, the UC301 includes

two open-collector transistor digital outputs to enable / disable the critical and noncritical loads, an RTD analog input for room temperature measurement, a one-turn potentiometer to set the temperature threshold for overriding the critical loads and three dry-contact-switch digital inputs for uses that will be discussed later.

UC301 is mounted in the four-inch-wide track found in metal enclosure MH1400 or MH2400, as described in data sheet D454 and is powered by transformer X12425, also mounted in the same enclosure. These enclosures are attractive and are usually positioned next to the condominium's circuit breaker panel to reduce the length of wire runs.

Although the enabling and disabling of the critical and noncritical loads would conventionally be handled by utilizing a contactor for each circuit, model UC301 is capable of powering and driving up to two multiple power relay modules, model M24PPY, or powering and driving a circuit breaker driver, model BD55, which controls "POWERLINK" remote-controlled circuit breakers manufactured by the Square D Company. If the circuit breakers are originally

Square D breakers and can be exchanged for "POWERLINK" circuit breakers, then the use of model BD55 may be labor and cost effective since the ac power lines do not have to be re-routed. Otherwise, model M24PPY multiple relay modules can be used in series with the existing circuit breakers. Labor and cost savings will be realized by using either model M24PPY or BD55. Either one M24PPY or one BD55, whichever is selected, can be mounted in the same MH1400 enclosure as the UC301. If a second M24PPY is needed, a second enclosure is required.

When used in PLC systems, as described in Technical Reference Manual A234, the UC301 appears as a digital out, which controls both critical and noncritical loads; a digital in, which indicates the enable/disable status of the critical loads; and an analog in, which indicates the room temperature as measured by an RTD. If the room temperature goes below a selected threshold temperature, the UC301 will automatically enable the critical loads. When used in PLC systems in which the controller manufacturer serially interfaces with our model CD9FDM Command Synthesizer, additional information and commands can be communicated via PLC. This includes the ability to selectively turn the noncritical loads off without affecting the critical loads and being able to use the three digital inputs to indicate three different non-normal conditions. These digital inputs have a latching function to assure momentary inputs are reported.

Condominium Controllers can be intermixed in a PLC system with Unit Controllers and two-way and one-way Responders to achieve the most cost-effective solution to a given energy management task.

See A475 for information describing power input and signal input.

## Model M24PPY – Two DPDT 25-Ampere Relays + One SPST-NC 35-Ampere Relay For Use With Model UC301

Model M24PPY is a modular relay board similar to the power relay boards described in data sheet D454. It has two DPDT 25-ampere relays and one SPST-NC 35-ampere relay on a circuit board. This provides five contact outputs for handling four 25-ampere circuits and one 35-ampere circuit. The power to drive these three relays comes from model UC301. The two

digital-outs of model UC301 are connected to the coils of the M24PPY in such a way as to establish the critical vs. noncritical loads as desired. Two of the M24PPYs can be powered and driven by one UC301. M24PPY is 4" wide by 4.7" tall for mounting in MH1400 or MH2400.

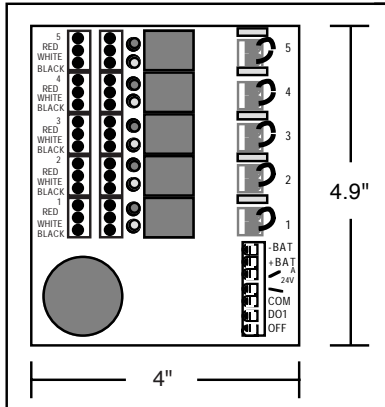

### MODEL BD55

#### DESCRIPTION

In energy management the conventional approach to remotely controlling electrical

loads is to install a contactor between the circuit breaker and the load being controlled. This necessitates installing a second electrical box to house the contactor someplace between the circuit breaker box and the load being controlled. In retrofit construction the re-routing of the ac wires to the contactor box and then to the load can be costly and unsightly. When the circuit breaker box is recessed, the re-routing of the ac wires can be even more difficult and costly.

The Square D Company has a circuit breaker marketed under the trade name of "POWERLINK" that allows remote control of the load by the circuit breaker itself. When the "POWERLINK" circuit breaker is substituted for the existing circuit breaker, the ac wires running to the load do not have to be re-routed. This makes for a simpler and less costly installation.

The "POWERLINK" circuit breakers can be manually turned on and off in the normal way by means of the conventional handle and will open power to the load if the current rating is exceeded. In addition, if the circuit breaker is in the closed (or ON) position, the power to the load can be interrupted and restored by means of control signals. The control signal opens or closes all contacts within the circuit breaker and does not move the handle of the breaker or trigger the overload circuit of the breaker.

The control signal for opening or closing the "POWERLINK"

#### FEATURES

- Five contacts control up to 10 circuit breakers
- Hard-wire interfaces with controllers
- Also interfaces with Functional Devices' PLC Responders and Condominium Controllers
- Reduces cost and labor of retrofit jobs
- Contains diagnostic LEDs
- Allows battery emergency override of breakers

### CIRCUIT BREAKER DRIVER



UL COMPONENT  
RECOGNIZED

circuit breakers has a current requirement of two amperes at 24 Vdc for 50 milliseconds, which is in excess of the capacity of most controlling instruments. This necessitates interface equipment between the controlling instrument and the circuit breakers.

The BD55 is intended for driving "POWERLINK" remote controlled circuit breakers. The BD55 accepts five contact closures from a controlling instrument (or open collector digital outputs from UC301) to open and close as many as ten of the circuit breakers, with each contact closure controlling up to two circuit breakers. Inputs for contact closures can be paralleled and the contacts can be allocated to critical vs. noncritical loads as desired. Closure of each controller contact opens the ac path within the circuit breaker and removal of the contact closure turns the circuit breaker back on. Aside from substituting the "POWERLINK" circuit breakers for the existing Square D breakers, no rewiring of the ac power is required. BD55 can be mounted in the four-inch-wide plastic track of Functional Devices' modular control housing MH1400 (surface mounted) or MH2400 (flush mounted). The modular housings are usually mounted next to the existing circuit breaker box. The wiring from the controlling instrument to the BD55 is Class II. A 120 Vac to 24 Vac transformer, X12425, is available for providing the 24 Vac to the BD55 and can be mounted within the modular housing.

The BD55 can be incorporated into an energy management system using either hard wiring or Power-Line Carrier components between the controller and the BD55.

The BD55 is 4" wide by 4 7/8" for mounting in MH1400 or MH2400 enclosure. See data sheet D450 for more information.

"POWERLINK" is a trademark of The Square D Company.

## MULTIPLE SWITCH READER

A requirement exists for monitoring multiple switch inputs at a single location. This includes monitoring many electric meters and water flow switches, which are typically at a given location in a condominium.

Commercially available equipment exists for counting multiple meter pulses, and for reporting this information back to a central location via hard wiring. Model UC311 can perform this same function, perform additional switch-reading functions and, in addition, eliminate the need for the hard-wired connections to the central location. The UC311 can monitor up to 16 meters and 16 digital inputs (which can be latching inputs) and report the status of these inputs back to the central location via Power-Line Carrier (PLC).

By means of DIP switches the UC311 can be programmed to assume up to 16 sequential PLC addresses starting at an address that is also selected by the DIP switches. A pair of inputs, consisting of a pulse counter and a digital input, constitute each PLC address and report as an AI and DI respectively.

If there is an ac power interruption to the UC311, the pulse counts are saved by automatically writing the data to electrically erasable memory (EEPROM) prior to the complete loss of power. This count is used as a starting value when the ac power is resumed. Use of this approach eliminates the need for batteries and their required maintenance. Since there is no ac power usage during the ac power interruption there is no loss of accuracy in electric meter reading.

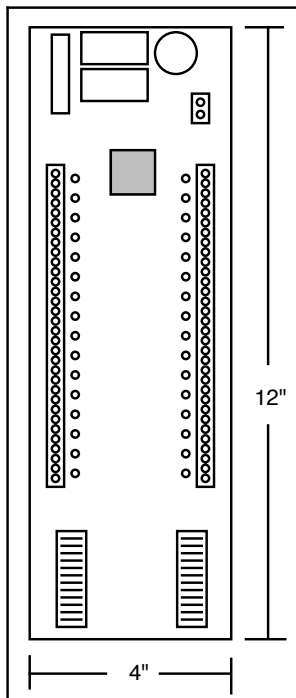

### MODEL UC311 - MULTIPLE SWITCH READER



**UL COMPONENT  
RECOGNIZED**

#### GENERAL OPERATION

UC311 is an Intelligent Responder designed to handle the multiple switch reading described above where the communication with the head-end controller is via power-line carrier (PLC).

In addition to the PLC interface with the ac line the UC311 hardware includes 32 inputs (switch, opto-isolator output or voltage). Sixteen inputs are treated as pulse counter inputs and 16 are treated as latched digital inputs (the deviation from normal is latched until a later PLC interrogation occurs).

The pulse counter input is modulo 2048 with prescaler settings selectable to divide by 1, 4, 16 or 256. All of the counter inputs must be divided by the same prescaler, which is controlled by DIP switch settings.

The latched digital inputs can be DIP switch selected to be latch-on-make or latch-on-break (all inputs having the same selection).

Each set of input terminals is accompanied by an LED to indicate the condition of that input. Other LEDs indicate the presence of power, receipt of PLC signal and the transmission of a PLC answer by the UC311.

Model UC311 is mounted in the four-inch-wide track found in metal enclosure MH1400 (surface mount) or MH2400 (flush mount) as described in data sheet D454. The UC311 is powered by a 24-volt transformer, X12425 (purchased separately), also mounted in the same enclosure. These enclosures are attractive and can be stacked vertically or horizontally to accommodate a large number of inputs. The UC311 can also be snapped into a four-inch-wide plastic track mounted in other enclosures.

The UC311 can be intermixed in a PLC system with Unit Controllers, Condominium Controllers, and two-way and one-way Responders to achieve the most cost-effective solution to a given energy management task. For more information see data sheet D457.

See A475 for information describing power input and signal input.