

BLASTER

Technical Reference Manual A426G

Supplemental Fire Alarm System

April 2005 393056



Functional Devices, Inc.
310 South Union Street
Russiaville, IN 46979
www.functionaldevices.com

Office: (765) 883-5538
Sales: (800) 888-5538
Fax: (765) 883-7505
Email: sales@functionaldevices.com

BLASTER

Supplemental Fire Alarm System

1. INTRODUCTION	PAGE 1
2. GENERAL OPERATION OF POWER LINE CARRIER SUPPLEMENTAL FIRE ALARM SYSTEM	PAGE 1, 2
3. INSTALLATION INSTRUCTIONS	PAGE 3, 4
4. CHECK-OUT PROCEDURE	PAGE 5
5. DATA SHEETS	
TSF2 Control Unit	PAGE 6
CTM Command Transmitter	PAGE 7
DP BLASTER Horn	PAGE 7
PI3 Signal Probe	PAGE 8
HT1 BLASTER Horn Tester	PAGE 8
LT1 Non-Alarm Tester	PAGE 9

1. INTRODUCTION

Although an apartment or condominium building has a fire alarm system which sounds bells in the hallways and public areas, it is often difficult for residents to hear these horns behind closed doors, through insulated walls and over television or air conditioner noises. Even increasing the sound level of the hallway bells far above the requirements of NFPA 72A often fails to meet the sound level recommendations of NFPA 72A for the family living units. The only sure way to meet the sound level recommendations of NFPA 72A for the family living units is to install alarm sounding devices within those units. In existing buildings, installing sounding devices within the family living units can be very expensive, disruptive and unattractive if it involves the running of new wires to the added sounding devices. These disadvantages, plus the fact that the sound level of a building alarm within the family living units is a recommendation of NFPA 72A, usually result in no action to supplement the building alarm system and a dangerous condition continues to exist without correction. There is a technology which allows the installation of sounding devices within the family living units without encountering the disadvantages listed above. It utilizes power line carrier (PLC) as a means of communication to the sounding devices within the family living units. PLC is the transfer of information over the existing ac wires of the building. It is like radio but it uses the existing ac wires as a conduction means. The information in this case is the fact that an alarm is in progress. When the building fire alarm system goes into alarm the Control Unit of the PLC system is triggered into action and it communicates with the PLC horn receivers which are plugged into an ac outlet within each family living unit. The horns sound an 85 dB sound level at 10 feet from the horn which is a far louder alarm than the 15 dB above average ambient which is recommended for inside the family living units by NFPA 72A.

The use of PLC altogether eliminates the running of new wires to the family living units. When the building fire alarm sounds, the Horns within the family living units also sound and the occupants are adequately warned of the existing danger. Functional Devices, Inc. offers a PLC Supplemental Fire Alarm system called the BLASTER for use in apartments and condominiums as described above. It is UL listed as a supplemental fire alarm system to be used along with alarm systems listed under NFPA 72A. The word supplemental means that it is a supplement to and is not to be used to satisfy the requirements of NFPA 72A. It is UL listed under UL Standard #985 Household Systems type UTOU which applies to the family living unit. NFPA 72A requires that the power for the fire alarm system be battery backed up. This is to assure that if the ac power to the building were to be lost the alarm system would still be capable of sounding the alarm. UL Standard #985, under which the BLASTER Supplemental Fire Alarm system is UL Listed, does not require battery back up. There is an argument that battery back up of the PLC supplemental alarm system is not as necessary as it is for the primary fire alarm system. If the ac power were to fail and the primary alarm system did not have battery backup then the alarm system would altogether fail to sound and the occupants would be in great jeopardy. If the ac power fails then the need for the supplemental alarm system is substantially reduced since most of the noise makers which might prevent the occupants from hearing the bells in the first place would be silent. Televisions, radios, air conditioners and kitchen appliances don't make any noise when they don't have ac power. During an ac power failure the occupants will be better able to hear the hallway bells of the building alarm system which does have battery back up.

2.0 GENERAL OPERATION OF POWER LINE CARRIER SUPPLEMENTAL FIRE ALARM SYSTEM

The BLASTER Supplemental Fire Alarm system utilizing Functional Devices' PLC equipment is composed of four main components in addition to the existing building ac power wiring. Referring to Drawing 1 shown below, there is a building alarm system, a Control Unit, a Command Transmitter, the existing ac wiring and many Horns in the family living units.

DRAWING 1

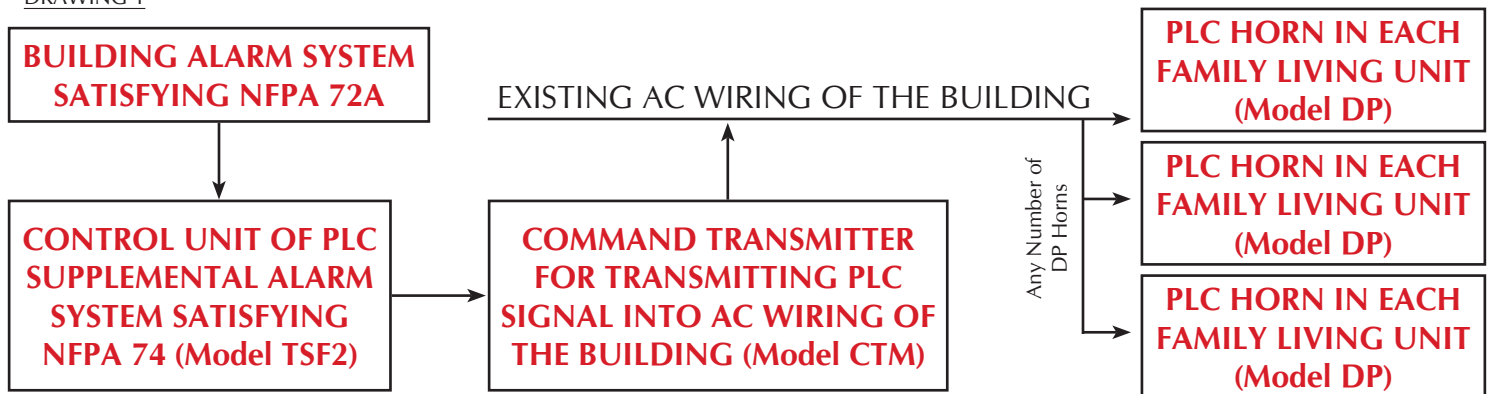

2.1 CONTROL UNIT TSF2

Either the voltage going to the bells of the existing building alarm system or a dry contact output (relay) added to the building alarm system is connected to the Control Unit, TSF2, to inform it that an alarm is in progress. This causes the TSF2 to generate the alarm signal which is transmitted by wire to the CTM and is amplified by the CTM and ultimately transmitted into the ac wiring of the building.

Each CTM can be driven by its own TSF2 or one TSF2 can drive several CTM's. The length of the wire run from the TSF2 to the CTM or from the TSF2 to the component of the existing alarm system must not in either case exceed 30 feet. This restriction usually results in the mounting of the TSF2 near to the CTM and may also result in the addition of a relay as part of the existing alarm system in close proximity to the TSF2. Sometimes in cases where there are voltage step-down transformers located on various floors of the building one TSF2 will be wired to drive the CTM on its floor and possibly also drive the CTMs on the floors above and below its floor.

2.2 COMMAND TRANSMITTER CTM

A CTM must be installed via a fused disconnect (5 to 30 amp) at the load side of each main disconnect supplying 120 Vac to the building. This includes the main disconnect(s) where 120 Vac first enters the building as well as the first disconnect following any voltage stepdown transformers outputting 120 Vac which are within the building. If the electric utility insists on metering then install a meter prior to the fused disconnect.

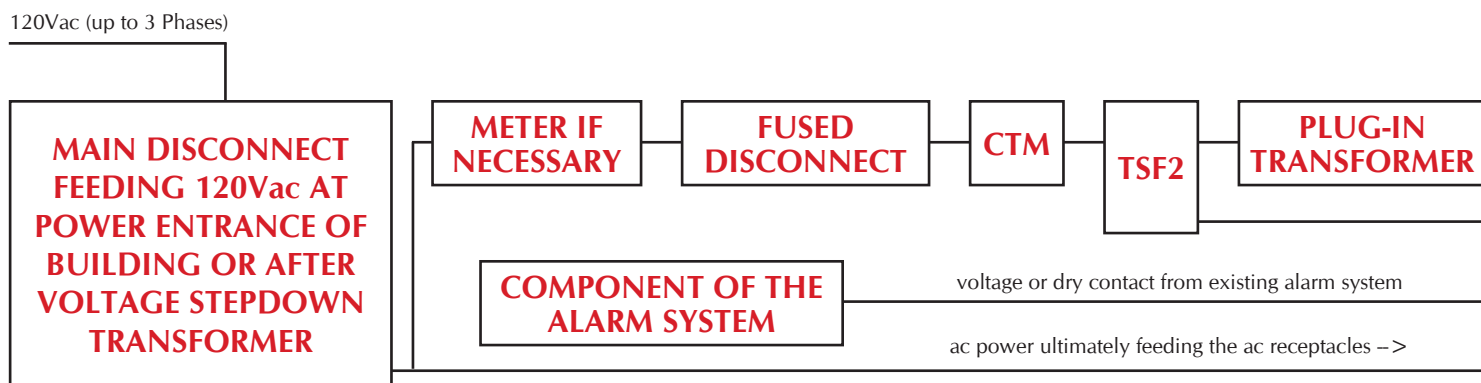

If no main disconnect immediately follows a voltage stepdown transformer then install the CTM through a fused disconnect directly to the output of the transformer. In any installation of a CTM, adhere to the local and national codes. The ten foot rule has been modified in the 1990 National Electrical Code to require the wire feed to an attached disconnect to be at least 10 % of the ampacity of the supplying disconnect. Refer to NEC 1990 Edition, Article 240-21 Exception #2. The installation must be performed by qualified personnel.

2.3 BLASTER HORNS DP

The DP Blaster Horn is to be plugged into an ac receptacle in the family living unit where it can be heard from all locations of the family living unit. The ac receptacle must not be controlled by a switch. Whenever the PLC system is in alarm the Horn will sound loudly. The Horn contains a tab with a mounting hole for securing the Horn to the ac receptacle using the screw which holds the cover plate in place.

3.0 INSTALLATION INSTRUCTIONS FOR SUPPLEMENTAL FIRE ALARM SYSTEM

THESE UNITS ARE TO BE INSTALLED BY QUALIFIED PERSONNEL ONLY. ALL OF THE FOLLOWING WIRING MUST BE INSTALLED ACCORDING TO THE NATIONAL ELECTRICAL CODE AND ANY LOCAL CODES.

3.1 MODEL TSF2 CONTROL UNIT

- This unit is to be mounted near the CTM.
- Mount the TSF2 so that the LED indicators next to the terminal strip are visible.
- Connect the screw terminals marked 24VAC of TSF2 to the supplied 120Vac to 24Vac transformer for ac power.
- Connect the signal output terminals of TSF2 to the signal input terminals (K, L) of the CTM transmitter (no polarity) with a maximum wire run of 30 feet (shielded 22 gauge or larger).
- Connect the dry contact input terminals of TSF2 to a contact closure on alarm from the fire alarm control panel, or connect the voltage input terminals of TSF2 to a voltage on alarm from the fire alarm control panel (6-30Vac or dc, no polarity) with a maximum wire run of 30 feet (shielded 22 gauge or larger).
- Green LED indicates Power On. Red LED indicates alarm sensed from alarm control panel and the TSF2 transmitting alarm signal.

3.2 MODEL CTM TRANSMITTER

• In the use of power line carrier equipment it is paramount to realize that the PLC signal amplitude is attenuated, or reduced, as it is propagated throughout a building's electrical system. Just as the 60 Hz power line voltage is attenuated over long runs of conductor, so is the PLC signal. To minimize the detrimental effects of signal reduction, proper location of the CTM(s) is essential. To insure proper operation of PLC:

3.2.1 The CTM absolutely must be installed within 10 feet wire length from the ac power source to which it is connected.

3.2.2 Connection must be through a 5 to 30 A fused disconnect to all phases of the ac service (not time lag or slow blow fuses and not a breaker).

3.2.3 A good equipment ground must be connected to the case of CTM.

3.2.4 The CTM absolutely must be installed downline from current transformers.

- CTM must be installed via a fused disconnect (5 to 30 amp) at the load side of each main disconnect supplying 120 Vac to the building. This includes the main disconnect(s) where 120 Vac first enters the building as well as the first disconnect following any voltage step-down transformers outputting 120 Vac which are within the building. If no main disconnect immediately follows the voltage stepdown transformer then install the CTM through a fused disconnect directly to the output of the transformer. If the electric utility insists on metering then install a meter prior to the fused disconnect. See Technical Reference Manual A426, Sections 2 & 3 and Data sheet D371.
- Using appropriate safety procedures connect the two terminals marked 120VAC to a nearby protected and disconnectable source of 120Vac 60Hz. This is the power in of CTM and 20 WATTS is required.
- Connect the terminal marked "N" to the NEUTRAL of the 120Vac.
- Connect the terminals marked "EL1, EL2, EL3" to a disconnect fused for 5-30 AMPS which is connected to all phases of the 120Vac that supply the family living units. In cases F & H, only make connections to EL1 and EL2. No ac power enters CTM through these connections.
- Connect the terminals (K, L) to the signal output terminals of Model TSF2. A maximum wire run of 30 feet (shielded 22 gauge or larger) is allowed.
- The metal housing of CTM must be well grounded.
- After TSF2 and CTM are powered, use PI3 and a DC meter to optimize the PLC signal level on the ac lines at CTM. The binary value of the dipswitch setting adjusts the value of a capacitor used to match the impedance of CTM to that of the ac line. Change the 4 position dipswitch in CTM by a trial and error method to optimize the voltage output of CTM. Typical P/P voltage at the transmitter is 12 to 20 volts. The most common optimized setting of the dipswitch is with only switch position 2 closed. See Data Sheet D369.

3.3 MODEL DP "BLASTER" HORN RECEIVER ALARM

- This unit is to be installed into a centrally located 120 Vac receptacle in each family living unit. The ac receptacle must not be controlled by a switch.
- Remove the screw holding the cover plate to the ac receptacle.
- Plug the Model DP into the ac receptacle.
- Reinsert the screw through the retaining tab and into the ac receptacle and tighten.

3.4 COMMONLY FOUND AC POWER SOURCES

CASE F

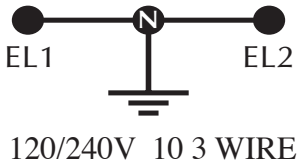

CASE G

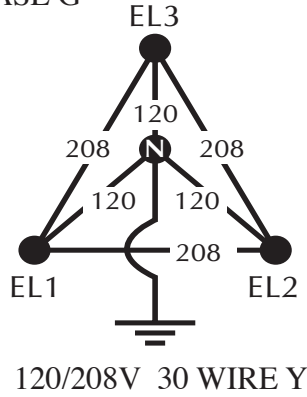

CASE H

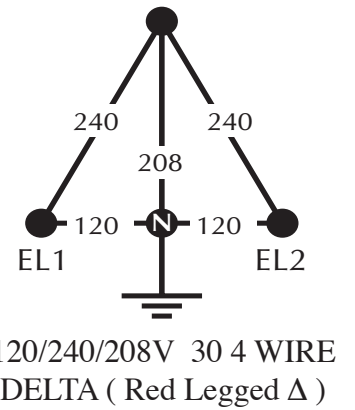

3.5 WIRE CONNECTIONS BETWEEN COMPONENTS

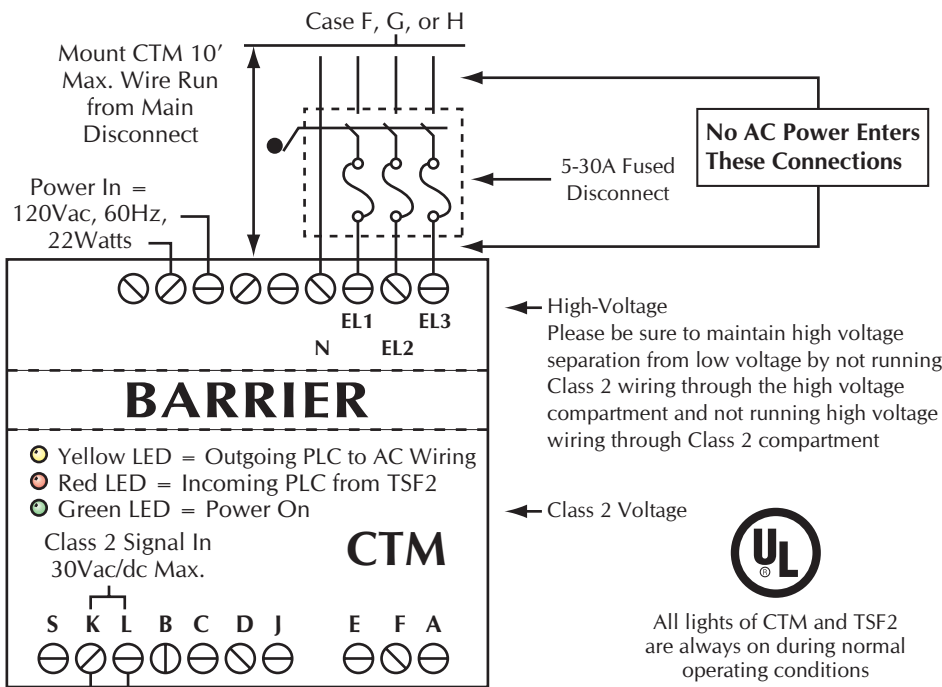

DP

DP Side View

Installing the Blaster Horn

- Remove center screw from ac receptacle
- Plug Blaster Horn in
- Re-insert screw through plastic tab on top of Blaster
- Tighten screw to secure Blaster to the receptacle

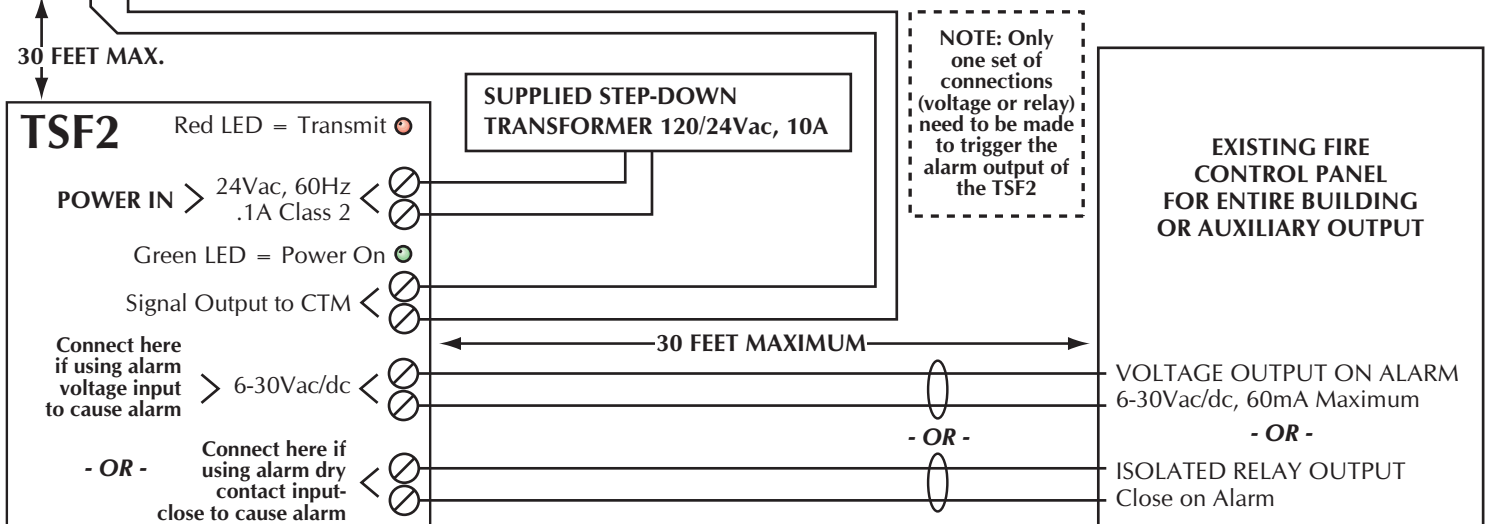

4. CHECK-OUT PROCEDURE

CHECK-OUT

Complete each of the steps below and fix any problems before proceeding to the following step. Otherwise, later check-out procedures will not be valid. Proceed with the check-out as follows:

Power the system. Green LED of the TSF2 should be on, red LED off.

If so If not → Check that there is ac power 120 Vac to the plug-in transformer. Check that there is approximately 24 Vac to the power in terminals of the TSF2.
↓

All three of the LED's of the CTM should be continuously on.

If so If not → Check that there is ac power 120 Vac to the upper terminals of CTM marked 120 Vac. Check that there is approximately 24 Vac to the lower terminals of CTM marked C & D. Check the continuity of the wire pair coming from the signal output terminals of the TSF2 and going to terminals K & L of CTM.
↓

By plugging in an LT1 Non Alarm Tester, perform a non alarm test of the PLC signal strength at several of the more remote family living units. The light of LT1 should light in all locations.

If so If not → Check the wiring between the TSF2 and the CTM. Check the wiring between the CTM and the 120 Vac disconnects. Check that all of the 120 Vac services powering the family living units do have CTM's connected (This includes all voltage stepdown transformers).
↓

Perform an alarm test on the building. All of the Blaster horns should sound.

If so If not → Some of the Blaster horns sounded.

↓
If so If not → Check the wiring between the building alarm system and TSF2. Temporarily substitute a direct short across the alarm dry contact input terminals to emulate the building alarm system (red LED on TSF2 should light). Check the wiring between the TSF2 and the CTM. Check the wiring between the CTM and the 120 Vac disconnects.
↓

If so If not → All of the Blaster horns sounded.

↓
If so If not → Check that all of the 120 Vac services which are powering horns do have CTM's connected (This includes all voltage stepdown transformers). Without reactivating the alarm system and using a Non Alarm Tester, LT1, check the adequacy of the PLC signal in each family living unit where the horn did not sound. Using Blaster Horn Tester, HT1, test the operation of all DP Horns which were located in family living units with sufficient PLC signal but did not sound during the test. If this fails to correct the problem then call the factory for assistance.
↓

CHECK-OUT PROCEDURE IS COMPLETE

5. COMPONENTS OF A PLC SUPPLEMENTAL FIRE ALARM SYSTEM

A Supplemental Fire Alarm System corrects a potential fire danger by supplementing the sound level of the existing fire alarm system so that it is more likely to be heard in the family living units of apartment and condominium buildings. Listed by Underwriters' Laboratories, Inc., the Supplemental Fire Alarm System supplements existing alarm systems with an 85 decibel Blaster horn (DP) placed in every family living unit. The DP is simply installed into the ac outlet. Then, using the wiring of the building as a transmission path, a Transmitter activates all of the horns whenever the existing alarm system goes into alarm.

The following Data Sheets on pages 6 through 8 describe and specify all of the components making up a PLC Supplemental Fire Alarm System and the test equipment.

BLASTER

Supplemental Fire Alarm System

TSF2 - Control Unit



DIMENSIONS

4.0" x 4.6" x 1.8" Deep



DESCRIPTION

TSF2 accepts a contact closure (relay) or voltage from an existing fire alarm system and generates PLC signals for injection onto 1 or 3 phase 120 Vac source(s) via CTM(s) thus enabling the signal to reach DP's and activate the horn within DP. During non-alarm times TSF2 outputs a non-alarm PLC signal to prevent cross talk between nearby buildings during alarm testing if they both have a BLASTER system. The non-alarm PLC signal also permits testing of the PLC communication means without sounding all of the DP's (see LT1 in D369).

FEATURES

- Continuous PLC transmission (even during non-alarm conditions) which:
 - Prevents crosstalk between buildings
 - Enables testing of PLC communication without sounding all of the DP's
- Easy to use diagnostic LED's

SPECIFICATIONS

- Labeled screw terminals for connection to power input, PLC signal output, alarm voltage trigger input & alarm contact trigger input.
- Power input is from supplied 120/24 Vac, 10 VA transformer (no polarity).
- Signal output is wired to terminals (K, L) of CTM (no polarity). TSF2 can drive up to 4 CTMs. Max. run = 30 feet (shielded 22 gauge or larger).
- Voltage on alarm input = 6-30 Vac or Vdc, 60 ma Max. (no polarity). Max. run = 30 feet (shielded 22 gauge or larger).
- Dry contact (relay) closure on alarm input (open circuit voltage = 5 Vdc, short circuit current = 1 ma. Max. run = 30 feet (22 gauge or larger).
- Either voltage or dry contact alarm input triggers alarm transmission to the DP's.
- Transmits non-alarm PLC signal during non-alarm times to prevent crosstalk between nearby buildings in case they both have a BLASTER system and to allow testing of PLC communication without sounding all of the DP's.
- Contains externally visible LED's which show the presence of power and outgoing PLC alarm signal.
- Operating temperature range 32 to 120° F, storage temperature range -40 to 221° F, humidity range 5 to 95% (noncondensing).
- One piece housing 4" X 4.6" X 1.8" of 94-5V flame retardant plastic, mountable via screw mounts.
- TSF2 is UL listed under Household Fire Warning System Accessory, UL Standard #985, Type UTOU.

BLASTER

Supplemental Fire Alarm System

CTM - Command Transmitter



DIMENSIONS

14.5" x 7.7" x 3.9" Deep

DESCRIPTION

The CTM amplifies the PLC signal being generated by a TSF2 Control Unit and then injects that signal onto all phases of the ac wiring right at the main 120 Vac disconnects. See Technical Reference Manual A426G, Section 2.2 for required locations.

FEATURES

- Transmits into any 120Vac line
- Easy to use diagnostic LED's
- Signal injection into all phases of 120Vac
- Injects PLC signal on energized lines with respect to neutral

SPECIFICATIONS

- Housed in 14.5" x 7.7" x 3.9" metal enclosure.
- 120Vac, 20 watt power input.
- Five watt minimum power output into 10 ohm load.
- PLC signal injection into a maximum of three phases EL1, EL2 & EL3 (60 Hz ac power does not enter through these connections).
- Contains externally visible LED's which show the presence of outgoing PLC signal to ac wiring, presence of PLC signal from the TSF2 Control Unit, and the presence of ac power.
- Contains 4 position dipswitch to maximize PLC output voltage.
- Operating temperature range -30 F to 150° F, storage temperature range -40 F to 221° F, humidity range 5 to 95% (noncondensing).
- CTM is UL listed under Household Fire Warning System Accessory, UL Standard #985, Type UTOU.

BLASTER

Supplemental Fire Alarm System

DP - Blaster Horn Receiver



DIMENSIONS

4.0" x 3.0" x 2.2" Deep

DESCRIPTION

Located in each family living unit, the DP Horn Receivers are plugged into the ac wall outlets and secured. Each DP sounds off it's internal horn (85dB at 10ft.) whenever the existing fire alarm system goes into alarm. The existing fire alarm system triggers the TSF2 Control Unit by outputting a contact closure (relay output) or a voltage (intended for the public area horns). When the existing fire alarm triggers the TSF2 the TSF2 generates an alarm PLC signal that is sent (over a wire pair) to one or more Command Transmitter where it is amplified and then injected onto the 120Vac wires. This signal permeates the ac power system of the entire building to trigger all DP Horn Receivers into alarm.

SPECIFICATIONS

- Pulsating horn sound output equals 85 dB or greater at 10 ft.
- Standard Two prong 120Vac plug in connection.
- Power input = 120 Vac, 60 Hz, 0.1 Amps.
- Operating temperature range 30 to 120° F, storage temperature range -40 to 221° F, humidity range 5 to 95% (noncondensing).
- One piece housing 4" X 3" X 2.2" of 94-5V flame retardant plastic, mountable via screw tab.
- DP is UL listed under Household Fire Warning System Accessory, UL Standard #985, Type UTOU.

BLASTER

Supplemental Fire Alarm System

Test Instruments



Model HT1 - Blaster Horn Tester

PLUG HORN TO BE TESTED HERE

The HT1 contains an isolation network that makes it possible to test DP Blaster Horns without triggering the rest of the horns installed in the building. Plug the Blaster Horn into the ac outlet. The horn should not sound. Push the test button. If the horn sounds then it is working properly. HT1 contains a circuit reset button which must be depressed if it pops out due to overload.



Model LT1 - Non-Alarm Tester

INDICATOR LIGHT

Non-Alarm Tester, LT1, is activated by the non-alarm signal being continuously output during the non-alarm times. It has slightly less sensitivity than does Blaster Horn DP. If the indicator light is lit when LT1 is plugged into a family living unit receptacle during a non-alarm time then the PLC signal strength at that location is sufficient to activate a DP Blaster Horn during an alarm. LT1 can be used to pretest a building prior to an actual test of the horns or to verify that there is sufficient PLC signal strength in case a Blaster Horn fails to sound during a test.



Model PI3 - Signal Probe

BLACK WIRE: To energized line (120Vac Max)

GREEN WIRE: To neutral

PI3 is used to sample the PLC signal so that it can be measured by a DC meter. It passes through the PLC signal but eliminates the 60 Hz component. The DC meter can only be used when the PLC signal amplitude is above several volts peak to peak (P/P) as it is at the CTM. Connect the input clip leads as indicated in the drawing at left. If an oscilloscope is available then connect from terminal "COM" to terminal "RF". This makes it possible to measure signal strength at the BLASTER. Since the voltage output of a CTM Transmitter can be optimized using a dipswitch contained within the Transmitter, the PI3 is useful in monitoring the voltage output as the dipswitch is being changed. After varying the dipswitch to optimize the voltage (see the trial and error method on page 5 of A248), calculate the P/P voltage using the DC meter by adding 0.6 volts and then multiplying by 2.