

MH1200 Series

Metal Housing, NEMA 1, 8.30" H x 7.70" W x 3.90" D

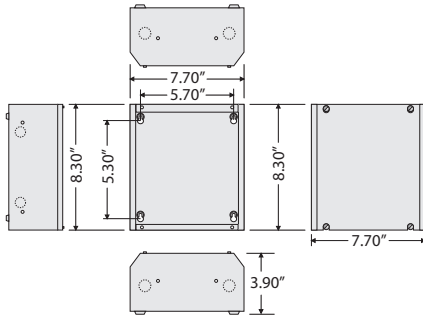

Specifications

Construction: 18 Gauge Steel

Weight: 3.50 lbs.

Cover Type: Screw Down Cover

Approvals: UL Listed, C-UL, CE Approved, RoHS

Notes:

- Consult factory for custom colors.

Enclosure



MH1200 Series Assemblies

Model #	Enclosure	Mounting Track
MH1200	MH1200	
MH1210	MH1200	MT4-8
MH1220	MH1200	MT212-8