

**NETWORK COMPATIBLE RELAY**

**RIBTW2402B-LN**

LonWorks® Twisted-Pair FT-10 Network Enclosed  
Dual I/O Device: One Binary Output (20 Amp Relay SPDT), One Binary Input (Dry Contact Class 2); 24 Vac/dc or 208-277 Vac Power Input

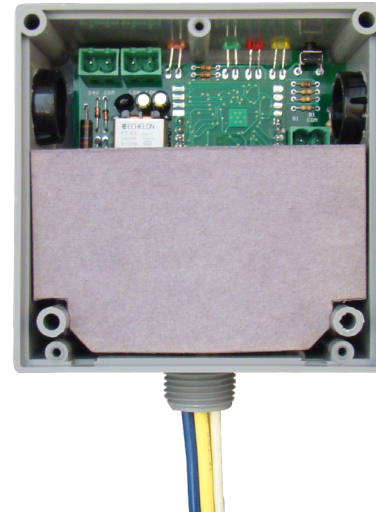
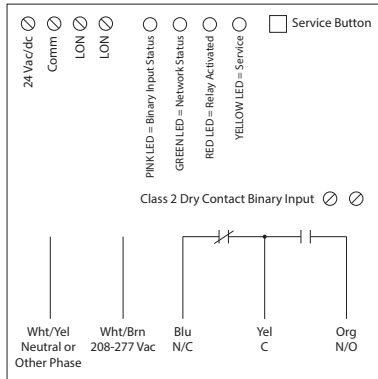

**SPECIFICATIONS**

- # Relays & Contact Type:** One (1) SPDT Continuous Duty Coil
- Expected Relay Life:** 10 million cycles minimum mechanical
- Operating Temperature:** -30 to 140° F
- Humidity Range:** 5 to 95% (noncondensing)
- Operate Time:** 18ms
- Green LED:** Network Status
- Red LED:** Relay Status
- Yellow LED:** Service Status
- Pink LED:** Binary Input Status
- Dimensions:** 4.00" x 4.00" x 1.80" with .50" NPT Nipple
- Wires:** 16", 600V Rated
- Approvals:** FCC, LonMark®, CE, RoHS, UL Listed, UL916, C-UL
- Housing Rating:** UL Accepted for Use in Plenum, NEMA 4
- Gold Flash:** No
- Override Switch:** No

- Contact Ratings:**
  - 20 Amp Resistive @ 277 Vac
  - 20 Amp Ballast @ 120/277 Vac (N/O)
  - 20 Amp Ballast @ 277 Vac (N/C)
  - 16 Amp Electronic Ballast @ 277 Vac (N/O)
  - 10 Amp Tungsten @ 120 Vac (N/O)
  - 1110 VA Pilot Duty @ 277 Vac
  - 770 VA Pilot Duty @ 120 Vac
  - 2 HP @ 277 Vac
  - 1 HP @ 120 Vac

**Power Input:** 24 Vac/dc; 208-277 Vac; 50-60 Hz

- Notes:**
- Order with P1 option by adding "-P1" to end of model number. The P1 option is pre-programmed to allow dry contact binary input to command the relay. Contact closure on the BI will activate relay.
  - When connecting 24 Vac to both the RIB(s) and a half-wave device, damage to device can occur.
    - Option 1: Use separate transformers for each device.
    - Option 2: Add diode between devices, see Option 2 note below. ^^

- Channel:** TP/FT-10
- Transceiver Type:** FT5000 Smart Transceiver
- Transceiver Compatibility:** FT3120 / FT3150, FTT-10 / FTT-10A, and LPT-10 / LPT-11 Transceivers
- Functional Blocks:**
  - 0000 Node Object
  - 0004 Closed Loop Actuator Object
  - 0001 Open Loop Sensor Object
- Downloadable Files:** PDF, XIF, APB, VSS and NXE available on website.

DESCRIPTION	SNVT NAME	SNVT TYPE
Command to open/close relay	nvi Value	SNVT_switch
Command status of relay	nvo Value Fb	SNVT_switch
Default state of relay on/off	nci Default	SNVT_switch
Communication timer	nci Max Receive T	SNVT_elapsed_tm
Status of Binary Input	nvo Value	SNVT_switch
Invert status of Binary Input	nci Invert	SNVT_lev_disc
Max time between updates	nci Max Send T	SNVT_elapsed_tm
Min time between updates	nci Min Send T	SNVT_elapsed_tm

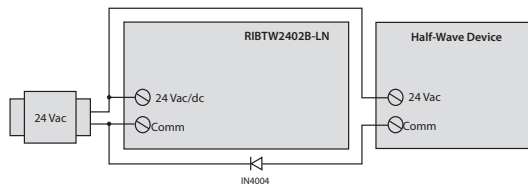

^^ Option 2: Add diode on 24 Vac power (Comm) interconnection between devices. Band on diode faces towards RIB(s).

The relay will go to the default state when the communication timer times out. Setting the timer value to zero will cause the communication to never time out.

It is recommended to put a value in nci Max Send T to ensure the RIB re-synchronizes itself on the network after power loss. It is the responsibility of the user to ensure this value does not cause conflicts in network traffic. (No value = No "heartbeat" updates / no re-synchronization; Low Value = Many updates but may cause many traffic collisions; High value = Few updates but many less collisions.)

