

**UL924 / 10 AMP AUTOMATIC LOAD CONTROL RELAY**

**ESRB**

UL924 Emergency Lighting Automatic Load Control Relay, 10 Amp SPST, Universal 120-277 Vac, 0-10 Vdc Dimmer Override, Dry Contact Fire Alarm Interface

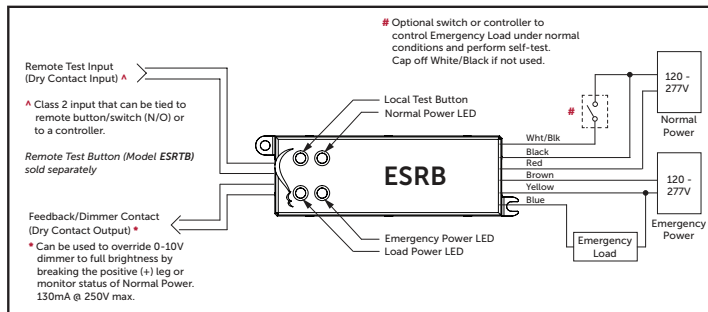

**SPECIFICATIONS**

- # Relays & Contact Type:** One (1) SPST Continuous Duty Coil
- Expected Relay Life:** 10 million cycles minimum mechanical
- Operating Temperature:** -30 to 140° F
- Operate Time:** 18ms
- LED:** Green = Normal Power  
Red = Emergency Power  
Yellow = Load Power
- Dimensions:** 1.68"H x 5.50"W x 1.32"D
- Housing Detail:** See **Housing G** in housing guide for dimensions
- Origin:** Made of US and non-US parts
- Wires:** 16", 600V Rated
- Approvals:** UL Listed, UL924, C-UL, CE, RoHS
- Gold Flash:** No
- Override (Test Switch):** Yes
- Humidity Range:** 5-95%(noncondensing)

- Coil Current:**  
Normal Power = 24 mA max  
Emergency Power = 118 mA max
- Coil Voltage Input:**  
Emergency Input: 120-277 Vac (50/60 Hz)  
Normal Input: 120-277 Vac (50/60 Hz)
- Relay Contact Ratings:**  
10 Amp Magnetic Ballast @ 277 Vac  
10 Amp Electronic Ballast @ 277 Vac  
10 Amp Tungstun @ 120V
- Feedback/Dimmer Override Contact:**  
130 mA @ 250V Max

**TESTING**

- Initial Test for Correct Wiring**  
Apply Emergency Power to the Emergency Power Input and Normal Power to the Normal Power Input. (If using the Wall Switch Input (Wht/Blk wire), apply Normal Power to the switch also, but keep the switch OFF/OPEN.)
  - a. The Red LED (Emergency Power available) should be ON.
  - b. The Green LED (Normal Power available) should be ON.
  - c. The Yellow LED (Load Status) should be OFF.
  - d. The Load should be OFF.
  - e. The Feedback/Dimmer Contact should be CLOSED.
- Local Test Button**
  1. Turn wall switch OFF. Emergency light should be OFF.
  2. Press and hold "Local Test Button"
  3. Emergency light should turn ON.
  4. Release "Local Test Button" and emergency light should turn OFF.
- Remote Test Button (Model ESRTB - sold separately)**
  1. Turn wall switch OFF. Emergency light should be OFF.
  2. Press and hold "Remote Test Button"
  3. Emergency light should turn ON.
  4. Release "Remote Test Button" and emergency light should turn OFF.
- Wall Switch or Controller Contact**
  1. Turn ON switch if not already on.
  2. Emergency light should turn ON.
  3. Turn wall switch OFF.
  4. Emergency light will remain on for two seconds before turning OFF.

**AUTOMATIC LOAD CONTROL RELAYS & DIMMING OVERRIDE APPLICATION**

With our Automatic Load Control Relays (ALCR), you will complete your emergency lighting application as specified. Designed specifically for applications that require emergency load to be switched during a loss of normal power, creating a path to illuminate your emergency fixture.

**TROUBLESHOOTING**

CONDITION	ACTION
Red LED is OFF	<ul style="list-style-type: none"> <li>• Check Emergency Power Input wiring (BROWN and YELLOW wires) and voltage.</li> </ul>
Green LED is OFF	<ul style="list-style-type: none"> <li>• Check Normal Power Input wiring (BLACK and RED wires) and voltage.</li> </ul>
Yellow LED is ON but Load is OFF	<ul style="list-style-type: none"> <li>• Check Load wiring (BLUE wire and Load's neutral).</li> <li>• Verify Load's operating voltage is the same as the Emergency Power Input Voltage.</li> <li>• Check bulbs and ballast.</li> <li>• Replace unit.</li> </ul>
Load is ON but Yellow LED is OFF	<ul style="list-style-type: none"> <li>• Replace unit.</li> </ul>
Yellow LED and Load do not turn on when being tested	<ul style="list-style-type: none"> <li>• Check bulbs and ballast.</li> <li>• Check wiring connections if using a remote test option.</li> <li>• Press local test button on the unit.</li> <li>• Replace unit.</li> </ul>
Yellow LED and Load will not turn OFF	<ul style="list-style-type: none"> <li>• Verify status of Normal Power Input.</li> <li>• Open Wall Switch Input.</li> <li>• Verify that no test inputs are stuck closed. (i.e. Remote Test Input is not closed).</li> </ul>

UL924 / 10 AMP AUTOMATIC LOAD CONTROL RELAY

# Typical Applications

## USING EMERGENCY LIGHTING AS NORMAL LIGHTING

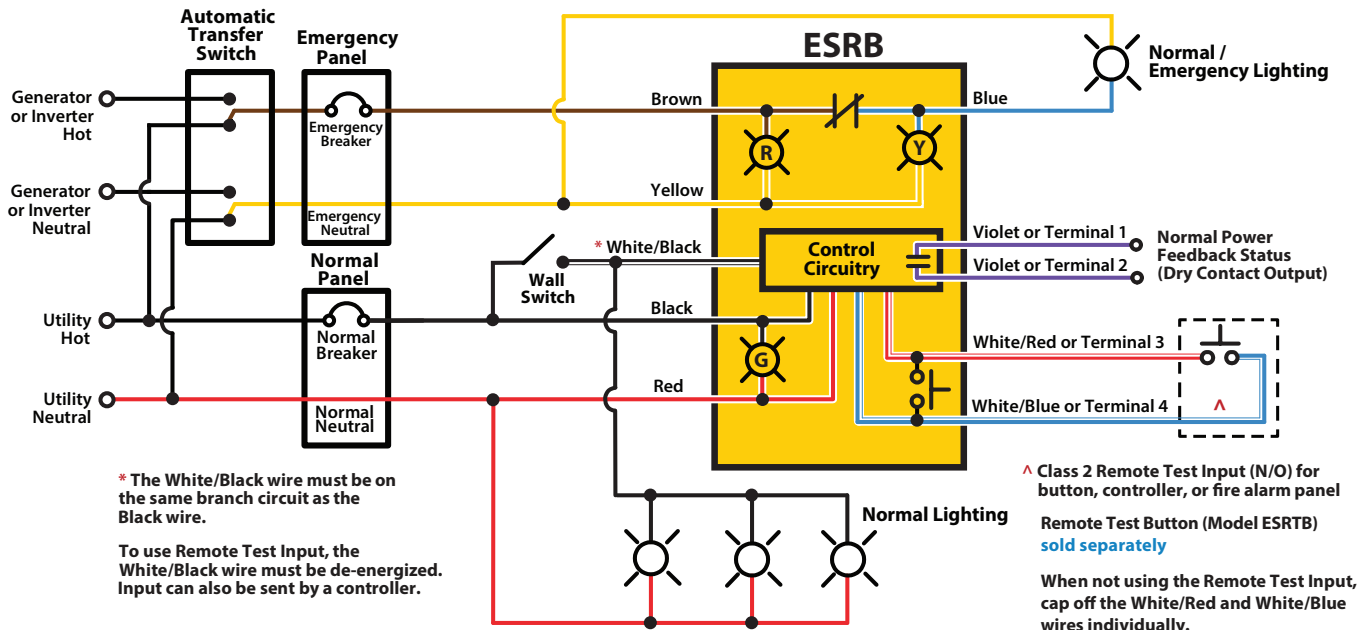

## OVERRIDING A 0-10VDC DIMMER

